



HUMAN FACTORS EVALUATION OF TECHNOLOGY INTENDED TO ADDRESS BLADE-CONTACT INJURIES WITH TABLE SAWS

JULY 2011

Timothy P. Smith
Engineering Psychologist
Division of Human Factors
Directorate for Engineering Sciences
U.S. Consumer Product Safety Commission
4330 East West Highway
Bethesda, MD 20814
(301) 504-7691, tsmith@cpsc.gov

This report has not been reviewed or approved by the Commission and may not reflect its views.

CONTENTS

BACKGROUND	1
BASIC TABLE SAW OPERATIONS	3
BLADE-CONTACT INJURIES AND SCENARIOS	4
TABLE SAW STANDARDS	6
<i>Voluntary Standards</i>	6
<i>Mandatory Standards</i>	6
TRADITIONAL BLADE GUARD SYSTEMS	7
<i>Blade Guards</i>	7
<i>Kickback Prevention Devices</i>	7
<i>Consumer Use of Traditional Blade Guard Systems</i>	8
NEWER BLADE GUARD SYSTEMS	10
<i>Sample System Installation and Removal</i>	11
<i>Sample System Use and Operability</i>	13
INJURY MITIGATION SYSTEMS	14
<i>Sample System Installation and Removal</i>	15
<i>Sample System Use and Operability</i>	16
CONCLUSIONS	17
REFERENCES	18

BACKGROUND

Table saws are stationary power tools used for the straight sawing of various materials but primarily wood. In essence, a table saw consists of a table that sits on a base and through which a spinning blade protrudes. To make a cut, the table saw operator places the workpiece on the table, and, typically guided by a rip fence or miter gauge, slides the workpiece into the blade (see Figure 1). According to the Power Tool Institute (2002), an organization that represents members of the power tool industry, table saws are one of the most commonly used stationary power tools in any woodworking shop.

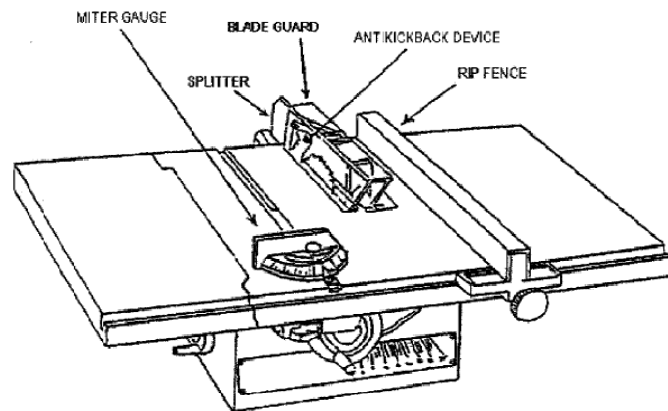

FIGURE 1. Typical table saw components.

Standard safety devices on table saws are designed to prevent the saw blade—or pieces of the blade should it shatter or a tooth become loose—from making contact with the operator and to prevent the saw blade from imparting its kinetic energy to the workpiece and throwing the workpiece back towards the operator, a phenomena known as kickback. These safety devices generally fall into two basic categories: blade guards and kickback prevention devices.

Blade guards surround the exposed blade and function as a physical barrier between the blade and the operator. Kickback prevention devices include splitters, riving knives, and anti-kickback pawls. A splitter, also commonly called a spreader, is typically a flat piece of metal aligned directly behind the saw blade that rides within the cut, or kerf, of a workpiece that is being fed through the blade. This prevents the workpiece from closing up and pinching the blade, which can cause the workpiece to be thrown back toward the operator. Riving knives are curved metal plates that are similar to and perform the same function as splitters, but tend to sit closer to the blade, rise no higher than the top of the blade, and attach to the arbor assembly¹ so that they move with the blade. Anti-kickback pawls—sometimes referred to as anti-kickback fingers or devices—consist of two hinged and barbed pieces of metal that allow passage of the workpiece but will dig into the workpiece if it begins to move back toward the operator.

Traditionally, table saws sold in the United States have employed a blade guard system that combines a blade guard, splitter, and anti-kickback pawls as a single unit that is bolted to the saw's carriage assembly (Adams, 2010; Mehler, 2003; Tolpin, 2004; see Figure 1). The blade guard was a single rectangular piece of transparent plastic often referred to as a “hood.” The splitter generally served as the main support and connection point for the blade guard and the anti-kickback pawls. Thus, removing the splitter for any reason necessarily removed the rest of the blade guard system and the protections those devices might offer.

¹ The arbor assembly includes the arbor, which is the metal shaft that holds the saw blade.

In 2007, a new modular blade guard system was introduced to the U.S. market as part of a commercially available, consumer-oriented table saw.² The new guard design represented the efforts of a Joint Venture (JV) group formed by major table saw manufacturers to address blade contact injuries on table saws. The JV group's intention was to increase blade guard usage by improving the functionality and effectiveness of the traditional blade guard.

A table saw with a blade-contact detection and reaction system was introduced to the U.S. market as part of a commercially available, consumer-oriented table saw in 2008. This detection and reaction system stops and retracts the saw blade in milliseconds upon contact with flesh, such as the finger of a table saw operator. The system was introduced to the U.S. market in 2005 by a single company, but at that time the system was only available on professional-level table saws.

CPSC staff was directed to initiate a project to collect information on emerging technologies intended to prevent and reduce blade-contact injuries. In 2009, in support of this project, staff of the CPSC's Division of Human Factors completed informal assessments of the new blade guard design and the blade-contact detection and reaction system. This report describes the results of those assessments and discusses the potential effectiveness of these technologies at addressing blade-contact injuries in general.

² Consumer-oriented table saws are available at home power tool retailers, such as Home Depot and Amazon.com, and are often reviewed by popular trade magazines, such as *Fine Woodworking* and *Popular Woodworking*.

BASIC TABLE SAW OPERATIONS

The most basic and common cutting operations performed on a table saw are rip cuts (“ripping”) and crosscuts (“crosscutting”). Ripping involves reducing the width of a workpiece by sawing along its length, a cut that is often referred to as sawing “with the grain” (see Figure 2). When ripping, the workpiece is placed flat on the table with one long side against a rip fence (see Figure 1), which is set parallel to the saw blade. The operator then slowly pushes the workpiece against the fence and through the saw blade. A push stick, or pusher, is often used during rip cuts—especially narrow rip cuts—to help keep one’s hand away from the blade. By angling the blade relative to the surface of the table, operators can perform “bevel” rip cuts.

Crosscutting shortens the length of a workpiece by sawing across its width, or “across the grain.” To perform a crosscut, the workpiece typically is placed against a miter gauge or other sliding jig to keep the workpiece secure (see Figure 1). The miter gauge slides in a track and is slowly pushed forward, feeding the workpiece through the blade. The miter gauge can be angled relative to the blade to perform “miter” cuts. The ability to adjust the angle of the blade relative to the table surface allows for bevel crosscuts, as well as cuts that are simultaneously mitered and beveled, known as “compound” cuts.

Although less common than ripping and crosscutting, other common woodworking cuts that can be performed on a table saw are non-through cuts, which include any cut in which the saw blade does not extend through the top surface of the workpiece. Dadoes and rabbets are the most common forms of these cuts. A dado produces a simple channel or trough in the workpiece; dadoes that run the length of the workpiece rather than across its width are sometimes referred to as grooves (Tolpin, 2004). A rabbet is a similar rectangular non-through cut that is located at the edge or end of a workpiece.

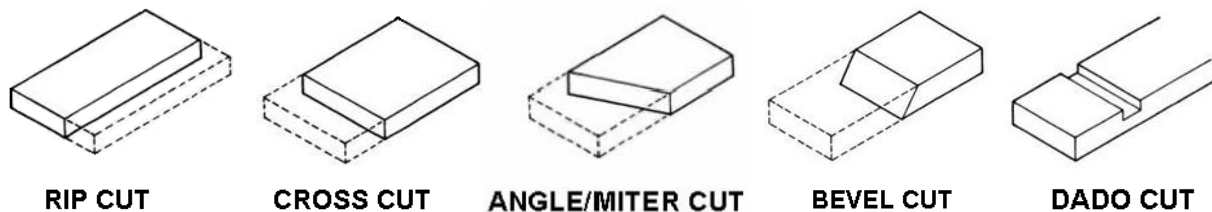

FIGURE 2. Some sample cutting operations.

BLADE-CONTACT INJURIES AND SCENARIOS

One of the primary hazards associated with table saws is direct contact between the operator and the saw blade. Such contact can result in lacerations, amputations, or similar injuries. In 2009, staff of the CPSC's Directorate for Epidemiology, Division of Hazard Analysis (EPHA), completed a survey of injuries that were associated with stationary saws and other unspecified saws and were treated in the emergency departments of National Electronic Injury Surveillance System (NEISS) hospitals between January 1, 2007 and December 31, 2008. Based on this survey, an estimated 66,900 injuries involving contact between the operator and the blade were treated in U.S. hospital emergency rooms during 2007 and 2008 combined (Chowdury & Paul, 2011). The most frequent injuries sustained were lacerations (65.9%), followed by fractures (12.4%) and amputations (12.0%). About two-thirds (66.5%) of the injuries occurred on a table saw without a blade guard attached, and the most common reason reported for the guard's absence was deliberate removal.

Many common and foreseeable scenarios are likely to lead to contact with the saw blade. For example:

- becoming distracted and inadvertently feeding the hand into the blade;
- losing one's balance from slipping, tripping, or overreaching, and inadvertently feeding the hand into the blade;
- reaching over or past an unguarded blade during a cut;
- removing cutoffs or brushing sawdust from the table while the blade is still spinning;
- losing control of slippery, very smooth, warped, or otherwise difficult-to-hold workpieces; and
- catching gloves, loose clothing, or jewelry on the spinning blade, which pulls the operator's hand into the blade.

Another common occurrence that could lead to blade contact is kickback. Based on the previously mentioned survey completed by EPHA staff, about 35 percent of the estimated 66,900 blade-contact injuries reportedly involved the workpiece kicking back or jumping during the cut. Kickback occurs most often when the workpiece binds in the spinning blade or contacts the rear portion of the spinning blade, which propels it back toward the consumer. This sudden movement, or any other unexpected movement of the workpiece, can cause the operator to lose control of the workpiece and to contact the saw blade inadvertently with the hand or arm. Additionally, if kickback occurs while the operator's hand is positioned behind the blade to hold, support, or remove the workpiece or cutoff, it might "pull" the operator's hand into the blade with the workpiece. Some examples of scenarios that could lead to kickback or workpiece ejection include (Adams, 2010; Mehler, 2003; Tolpin, 2004):

- the workpiece closing up on the blade after the cut;
- cutoffs becoming trapped under the guard or between the blade and the rip fence;

- pushing on the cutoff side of the workpiece during a rip cut;
- cutting freehand;
- releasing a workpiece before it has cleared the blade completely;
- stopping a cut midway through the workpiece; or
- making deep, wide non-through cuts, which tend to remove a lot of wood in a single pass.

TABLE SAW STANDARDS

VOLUNTARY STANDARDS

The U.S. voluntary consensus standard for table saws is UL 987, *Standard for Stationary and Fixed Electric Tools*. This standard was published by Underwriters Laboratories, Inc. (UL) in 1971 and has undergone several revisions, including the 7th edition, which is the most current. The original requirement for table saw guarding (section 40.9) specified that the complete guard consist of a hood, a spreader, and an antikickback device. The requirement specified that the guard hood completely enclose the sides and top portion of the saw blade above the table and that the guard automatically adjust to the thickness of the work piece. Blade guards that met this requirement were typically a hinged rectangular piece of clear plastic, as shown previously in Figure 1.

The 6th edition of UL 987, published in January 2005, added requirements for a riving knife and performance requirements for anti-kickback devices on table saws. This change essentially required all new table saws to employ a riving knife that is adjustable for all table saw operations (Section 40A.2). If the blade guard attaches to the riving knife, the device is considered a riving knife/spreader combination unit. This combination unit is considered to be in “spreader position” when the guard is attached and the unit is adjusted to permit through cuts; the unit is considered to be in “riving knife position” when the guard is not attached and the unit is adjusted to a position below the blade height above the table top to allow for non-through cuts.

The 7th edition of UL 987, published in November 2007, specified that the blade guard shall consist not of a hood, but of a top-barrier guarding element and two side-barrier guarding elements, one on each side of the blade (Section 42.2). The revised blade guard requirements reflect the new guard design developed by the Joint Venture. Additional requirements provide guidance on the rip fence, table insert, optional spreader, and instructions on making a push stick.

MANDATORY STANDARDS

Currently, the CPSC does not have any mandatory performance requirements for table saws. The U.S. Department of Labor’s Occupational Safety and Health Administration (OSHA) has regulations for table saws sold in commercial settings and used by the public in the course of employment. These regulations are codified at 29 CFR § 1910.213, *Woodworking Machinery Requirements*, and require that table saws include a blade guard, a spreader, and an antikickback device. The OSHA requirements for the blade guard, spreader, and antikickback devices are essentially identical to the requirements in the 5th edition of UL 987 before the revisions to the UL standard added requirements for a riving knife and the new blade guard design.

TRADITIONAL BLADE GUARD SYSTEMS

As noted earlier, prior to adoption of the 7th edition of UL 987, table saws sold in the United States traditionally had employed a blade guard system that combines the blade guard, splitter, and anti-kickback pawls as a single unit that is bolted to the saw's carriage assembly. The splitter generally served as the main support and connection point for the blade guard and the anti-kickback pawls.

BLADE GUARDS

Blade guards surround the exposed blade and function as a physical barrier between the blade and the consumer. These guards often are made of clear plastic but may be made of other materials. OSHA regulations and past editions of UL 987 require that a blade guard, or hood, completely enclose the portion of the saw blade above the table and above the material being cut, and that such a guard automatically adjust itself to the thickness of and remain in contact with the material being cut (29 CFR § 1910.213(c)(1) and (d)(1)).

In general, installed blade guards can effectively prevent most side, rear, and downward contact with the blade when used as instructed. These devices are less effective, and in many cases may be completely ineffective, at preventing contact with the blade resulting from front-end approaches toward the blade because this is the direction of approach of any workpiece that is fed into the blade, and blade guards generally are designed to allow passage of anything moving toward the front of the blade. For example, the fronts of blade guards are often shaped so that a workpiece fed into it causes the guard to rise and ride over the workpiece and allow access to the blade. Therefore, most blade guards will not prevent contact scenarios that involve approaches in this direction and tend to function more as a tactile proximity warning rather than a true guard that would physically prevent contact with the blade. Many non-kickback scenarios that could lead to blade contact, discussed earlier, would seem to involve approaches of this type.

KICKBACK PREVENTION DEVICES

Kickback prevention devices include splitters, riving knives, and anti-kickback pawls. A splitter, also known as a spreader, is typically a flat piece of metal that is aligned directly behind the saw blade. As the workpiece feeds through the blade, the splitter rides within the cut, or kerf, to prevent the cut sides of the workpiece from closing up and pinching the blade, which can cause the workpiece to be thrown back toward the operator. The height of a splitter generally is set based on the highest height of the blade, meaning that the splitter is often taller than the blade. Thus, splitters must be removed when performing non-through cuts, in which the top of the blade is used to cut a channel into the workpiece. Riving knives are curved steel plates that are similar to and perform the same function as splitters, but sit very close to the blade (see Figure 3), rise no higher than the top of the blade, and attach to the arbor assembly so that they move with the blade (Adams, 2010; Mehler, 2003). These characteristics allow riving knives to be used while making non-through cuts. Prior to changes to the UL standard in 2005 that explicitly permitted their use, riving knives were limited primarily to table saws sold in Europe. Anti-kickback pawls—sometimes referred to as anti-kickback fingers or devices—are intended to prevent movement of the workpiece opposite the feeding direction. They consist of two hinged and barbed pieces of metal that allow passage of the workpiece but will dig into the workpiece if it begins to move back toward the operator.

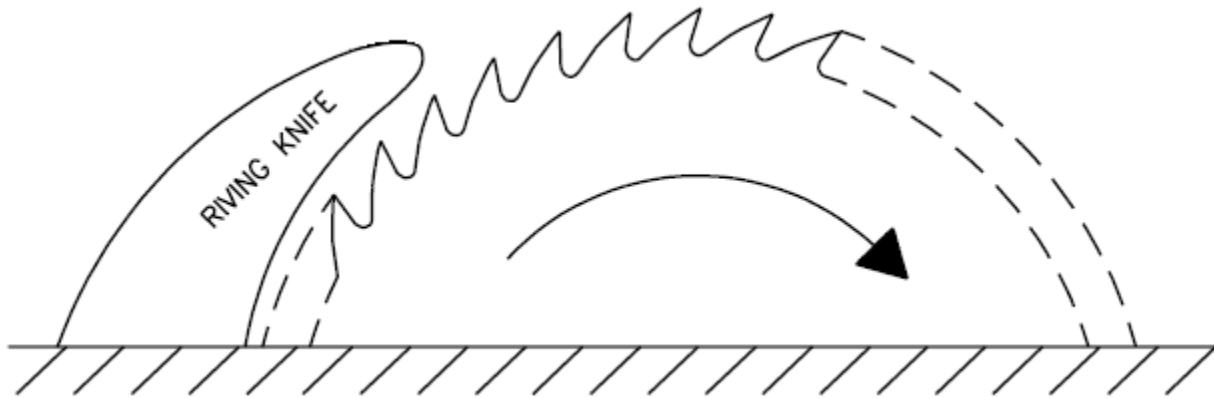

FIGURE 3. Riving knife positioned next to blade.

A properly installed splitter or riving knife may be the most effective way to prevent kickback because it limits workpiece access to the rear teeth of the saw blade (Adams, 2010; Mehler, 2003). Thus, in principle, these devices could address most blade-contact incidents associated with kickback when a splitter or riving knife was not used but could have been. Nevertheless, as mentioned earlier, splitters cannot be used when performing non-through cuts. In contrast, riving knives can rise, fall, and tilt with the blade, allowing them to be used while performing most through and non-through cuts. Moreover, riving knives tend to sit closer to the blade and enter the saw kerf sooner than a splitter, especially when the blade is set low. However, the effectiveness of both devices depends on the workpiece reaching them during the cut; thus, neither device is effective at preventing kickback or ejections associated with cutting short workpieces.

CONSUMER USE OF TRADITIONAL BLADE GUARD SYSTEMS

Ultimately, the effectiveness of any blade guard system depends on an operator's willingness to use it. Safety equipment that hinders one's ability to operate the product—for example, by increasing the time or effort required to perform the desired tasks—effectively “punishes” the operator for choosing to use the equipment and most likely will result in consumers bypassing, avoiding, or discarding it (Cushman & Rosenberg, 1991; Geller, 2001; Nussbaum, 1998; Trump, 1980; Woodson, 1998).³ This may be especially true for safety equipment with which operators would be required to interact repeatedly over the life of the product.

Several characteristics of traditional blade guard systems are likely to hinder table saw use and motivate consumers to remove them to make performing a cut simpler or easier. Some blade guards may jam on the leading edge of the workpiece, requiring the consumer to push the workpiece forcefully or to raise the guard manually. This scenario may be especially likely for sharply angled bevel cuts, and severe jamming could even drive the blade guard into the spinning blade. Because they act as a barrier between the consumer and the blade, blade guard systems invariably limit the visibility of the workpiece and the blade, to some extent, when the consumer is trying to set up or

³ This is similar to the concept of “cost of compliance” in warnings literature. One of the primary factors that affect whether consumers will comply with a recommended behavior in a warning is the cost of compliance, that is, the time, effort, and other “costs” associated with performing that behavior. Research has found that even small inconveniences can have a substantial negative impact on compliance (Riley, 2006).

make a cut; and many guards are not designed to stay up and out of the way to set up or align the cut easily. Sawdust also may accumulate in the guard, further restricting visibility. A blade guard system with a splitter that is not properly aligned with the blade can make feeding the workpiece through the blade increasingly difficult and can actually increase the likelihood of kickback by binding the workpiece between the blade and the rip fence (Mehler, 2003; Tolpin, 2004). If the splitter becomes bent, which can occur with use, this alignment is necessarily affected. Anti-kickback pawls can hinder the removal of a cutoff once a cut has been completed.

In addition to the above situations, which may motivate consumers to remove the blade guard system, some circumstances actually require that the guard system be removed to be able to perform the desired task. For example, many traditional blade guard systems limit the size of the workpiece that can be cut and restrict how close the rip fence can be brought to the blade, thereby preventing the use of the guard system with tall or oversized workpieces, or when performing thin rip cuts (Mehler, 2003; Tolpin, 2004). Traditional blade guard systems also typically employ a splitter, which means they cannot be used when performing non-through cuts, such as dadoes and rabbets. Because manufacturers recommend that blade guard systems be used whenever performing a through cut, these devices may have to be removed and reinstalled quite often between cuts. Experts claim that many traditional blade guard systems are difficult and time-consuming to remove and reinstall (Mehler, 2003; Tolpin, 2004), characteristics that are likely to discourage consumers from continuing to use the systems or from reinstalling them after they have been removed. Furthermore, many of the sawing tasks that absolutely require the guard system to be removed, tend to be somewhat more advanced or difficult, which suggests that experienced woodworkers may be more likely to have to remove the system. Because of their expertise and comfort level with table saws, these woodworkers may believe that reinstalling the guard system is not necessary for them, especially if they expect to remove the guard system again shortly thereafter, or they know that the task at hand will require frequent removal of the guard system.

NEWER BLADE GUARD SYSTEMS

In 2007, a new blade guard system that was consistent with the 7th Edition of the UL 987 standard entered the U.S. market as part of a commercially available, consumer-oriented table saw. The new blade guard system is a “modular” design that consists of an adjustable riving knife, a removable blade guard assembly, and removable anti-kickback pawls. The riving knife can be locked into high, middle, and “stored” positions (Robert Bosch Tool Corporation, 2007, p. 44), and, when locked into the high position, serves as the attachment point for the blade guard assembly and anti-kickback pawls. In the middle position, the riving knife acts as a more traditional riving knife. The guard assembly consists of a pair of independently hinged, plastic side barriers that attach to a metal upper barrier guard. The upper barrier guard is shaped similar to a tuning fork. No tools are required to install or remove this new blade guard system.

In 2009, the CPSC’s Mechanical Engineering and Human Factors staff obtained and examined a sample of a table saw with this new blade guard system. At the time, this was the only known table saw that employed a blade guard system of this type. Like traditional blade guard systems, the new blade guard design can effectively prevent most side, rear, and downward contact with the blade when used as instructed but cannot physically prevent contact with the blade resulting from front-end approaches toward the blade. The use of two independently hinged side guards can provide considerably more blade coverage than a solid guard during bevel cuts, by allowing one side to cover the blade even while the other side is raised or riding over the workpiece. This is illustrated in Figure 4, which simulates the interaction of a workpiece and the guard system when performing a bevel crosscut.⁴ This design is likely to offer similar advantages when cutting thick workpieces.

Another significant advantage of the new blade guard system is the use of a permanent, adjustable riving knife, rather than a removable splitter, as the primary kickback prevention device and support for the blade guard. Because the riving knife cannot be removed, it is likely to remain properly aligned with the blade at all times, thereby avoiding most of the potential for kickback associated with misaligned splitters and riving knives. Its permanence also means that the riving knife cannot be lost, and is always available to provide kickback protection in circumstances that allow its use. Because the riving knife can be used for both through and non-through cuts, consumers will not have to remove and reinstall the entire guard system when switching between non-through cuts and standard crosscuts and rip cuts. However, the consumer still would be required to remove and reinstall the blade guard assembly and anti-kickback pawls, and would

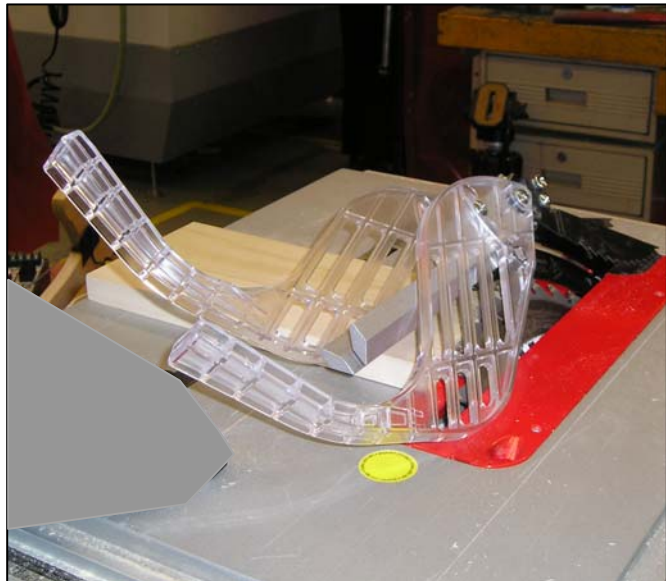

FIGURE 4. New blade guard system in bevel crosscut position.⁴

⁴ This figure is intended to illustrate the independent operation of the hinged side guards, not a true bevel crosscut. The miter gauge, which is obscured in the figure, normally would be placed against a workpiece during such a cut.

have to adjust the position of the riving knife. Although these tasks do not require tools, they do require some amount of time and effort that might become substantial if they must be done repeatedly.

SAMPLE SYSTEM INSTALLATION AND REMOVAL

As noted earlier, installing and removing a blade guard system might be one of the more common activities consumers will be required to perform while using a table saw, and these tasks can be difficult and time-consuming with traditional blade guard systems. Installing the new blade guard system involves three basic steps: positioning the riving knife, attaching the guard assembly to the riving knife, and attaching the anti-kickback pawls to the riving knife. Before positioning the riving knife, the consumer must first remove the table insert, or throat plate, raise the blade as high as possible, and set the blade perpendicular to the table. The riving knife locks into position

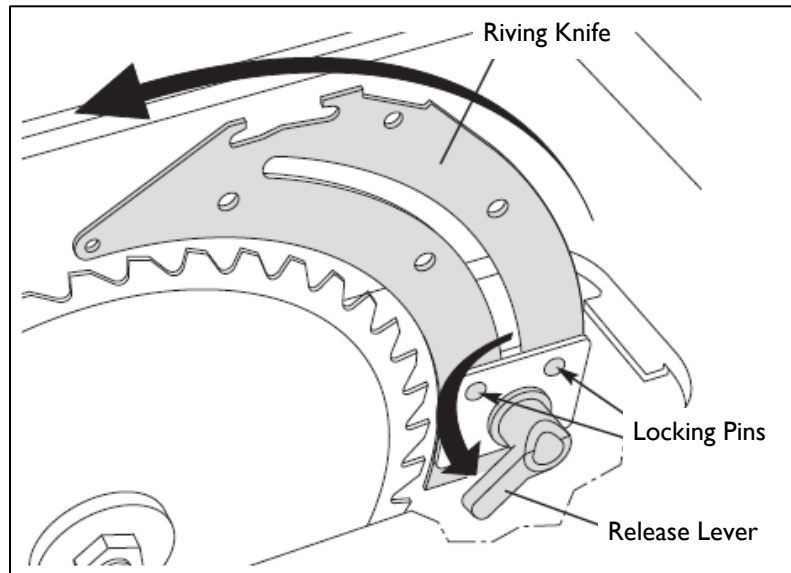

FIGURE 5. Positioning the riving knife of the new blade guard system. Adapted from *Bosch 4100/4100DG operating/safety instructions* (p. 26), by Robert Bosch Tool Corporation, 2007, Prospect, IL: Author. Copyright 2007 by Robert Bosch Tool Corporation. Used with permission.

using locking pins and a release lever that is located at its base. To position the riving knife, the consumer rotates the release lever open and slides the riving knife toward the lever to disengage it from the locking pins. The consumer can then raise the riving knife to its highest position, align its locking holes with the locking pins in the release mechanism, and rotate the release lever to lock the riving knife in place (see Figure 5). Once the riving knife is in place, the table insert can be replaced.

Although no tools are required to make these adjustments, Human Factors staff found that the release lever requires a considerable amount of force to disengage, and one's hand tends to rub against the blade while performing this action. Visually aligning the locking pins in the release lever with the desired locking holes is difficult, given the release lever's position below the surface of the table. This task can be simplified by applying pressure to the riving knife toward the locking pins while sliding the knife into position because this action causes the pins to naturally pop into the holes at the next position. The operating instructions that accompany the saw, however, do not instruct consumers to adjust the riving knife in this way. Rather, the instructions merely state that consumers should "[a]lign holes in riving knife with pins" (Robert Bosch Tool Corporation, 2007, p. 26).

Attaching the blade guard assembly to the riving knife requires the consumer to tilt and lower the assembly onto the attachment point so that the cross bar on the assembly hooks into the rear notch, while simultaneously holding the guard release lever up with the other hand (see Figure 6). The consumer then lowers the metal fork of the guard assembly so that it is parallel to the table and

presses on the guard release lever to lock the guard assembly in place. The requirement to tilt the rear portion of the guard down to install the guard assembly properly is not immediately obvious, but this task is accurately described in the operating instructions, and consumers should have little difficulty appropriately installing the guard assembly once aware of the proper procedure.

The anti-kickback pawls attach to the riving knife with a locking pin that can be opened or closed using a pair of opposing compression pads on the pawls. To properly install the pawls, the consumer squeezes the compression pads while nesting the device onto a flat recessed portion of the riving knife so that the locking pin aligns with the riving knife's locking hole (see Figure 7). The operating manual suggests that consumers might find this task easier if they position the device behind the recessed area and then slide it forward until it drops into place.

Releasing the compression pads engages the locking pin and locks the device in place.

Properly aligning and mounting the anti-kickback pawls onto the riving knife can be difficult initially because placing the pawls in the recessed portion of the riving knife does not automatically seat and align the locking pin with the corresponding locking hole in the riving knife. For proper alignment, the device must be brought to the riving knife at a specific angle, and it appears that consumers must learn the proper angle through trial and error. Nonetheless, installing the anti-kickback pawls becomes easier with practice.

Removing the new blade guard system involves removing the anti-kickback pawls and blade guard assembly; the sequence in which these devices are removed does not matter. To remove the anti-kickback pawls, the consumer squeezes the compression pads

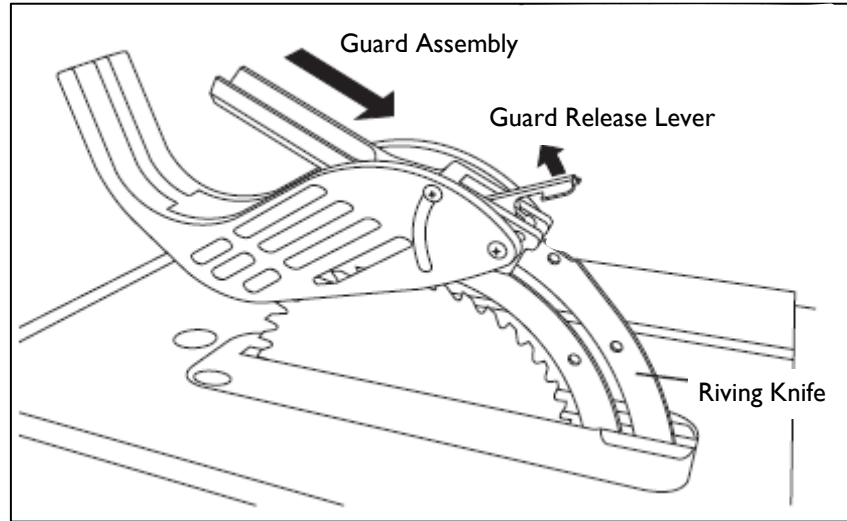

FIGURE 6. Attaching the blade guard assembly.

Adapted from *Bosch 4100/4100DG operating/safety instructions* (p. 28), by Robert Bosch Tool Corporation, 2007, Prospect, IL: Author. Copyright 2007 by Robert Bosch Tool Corporation. Used with permission.

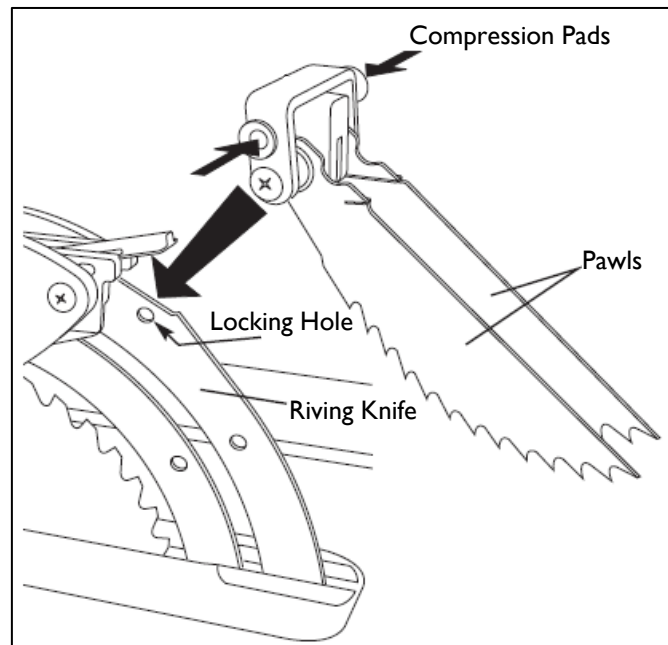

FIGURE 7. Installing the anti-kickback pawls.

Adapted from *Bosch 4100/4100DG operating/safety instructions* (p. 28), by Robert Bosch Tool Corporation, 2007, Prospect, IL: Author. Copyright 2007 by Robert Bosch Tool Corporation. Used with permission.

shown in Figure 7 and lifts the device from the riving knife. To remove the guard assembly, the consumer pulls up on the blade guard release lever and then lifts the front end of the guard assembly. Removing both devices is very simple. The riving knife can then be adjusted to the middle or stored position.

SAMPLE SYSTEM USE AND OPERABILITY

Human Factors staff performed some basic cuts with the sample table saw using various wood workpieces. The new blade guard system generally functioned well when performing basic crosscuts and rip cuts. The leading ends of the side guards did not jam into the front edge of the workpieces and easily rose up and rode over the tops of the workpieces. Because the top portion of the new blade guard system uses a metal fork that is open in the center, consumers have a direct, unobstructed view of the workpiece and blade while making these basic rip cuts and crosscuts. However, the metal fork and slatted plastic side guards still can obstruct one's view during beveled cuts. The side guards can be raised manually and "locked" into this raised position for setting up cuts, but the guards do not get completely out of the way, and their leading ends are quite long. These characteristics can block or interfere with a consumer's ability to get very close to perform precise alignments of the workpiece and the blade. Furthermore, once a cut is set up and the guards are lowered, the side guards still could prevent consumers from adequately observing a cut that is underway. The ability to fine-tune the workpiece position to properly align it with the blade immediately before initiating a cut may be especially important for compound cuts.

Human Factors staff also identified some circumstances in which the new blade guard system interfered with the ability to perform certain cutting operations. For example, the tilt of the guard assembly during bevel cuts can cause the long leading ends of the side guards to interfere with the smooth forward movement of consumers' hands as they feed a workpiece into the blade (see Figure 4, previously). Additionally, the workpiece would occasionally bind on the riving knife during 45-degree miter cuts, preventing consumers from being able to perform these cuts smoothly and avoid burning the workpiece. Like most traditional blade guard systems, the new blade guard assembly and anti-kickback pawls must be removed to cut tall or oversized workpieces. Human Factors staff also found that these components prevented the rip fence from moving very close to the blade to make narrow rip cuts. Thus, there remain circumstances in which a consumer would have to remove the new blade guard system.

INJURY MITIGATION SYSTEMS

One of the primary functions of blade guard systems is to prevent physical contact with the saw blade. Such systems are not intended to mitigate the often severe consequences of blade contact when it does occur. SawStop, LLC, recently developed a blade-contact detection and reaction system for table saws and, in 2008, released a contractor saw containing this system.

SawStop's blade-contact detection and reaction system represents a completely different approach to injury reduction than blade guard systems. Clearly, the SawStop system is not intended as a replacement for blade guards and kickback prevention devices. Blade guard systems, whether the new blade guard system, or the more traditional variety, are intended to reduce consumer exposure to the blade, and are important to help prevent kickback and blade contact in the first place. Yet, as noted earlier, sometimes a blade guard system cannot be used, leaving consumers with no blade-contact protection. Moreover, although systems should be designed to reduce the likelihood of error, total error elimination is unlikely, if not impossible (Hammer, 1972; Senders & Moray, 1991). For example, when ripping, consumers are told to focus their attention on where the workpiece meets the fence, rather than on the blade, because the workpiece must be against the fence for the entire cut (Mehler, 2003). This necessarily means that adequate attention cannot be given to the position of the hands relative to the blade. Even expert woodworkers can err, primarily because of their expertise. Behavior that is practiced over and over again increasingly requires less conscious attention. Thus, as experience and proficiency in a task increase, related behaviors become less deliberate and more automatic (Senders & Moray, 1991; Zimolong & Elke, 2006). As a result, experts can occasionally "slip" and automatically perform a highly learned behavior when such behavior is inappropriate (Nemeth, 2004; Reason, 1990), possibly resulting in blade contact. SawStop's blade-contact detection and reaction system, therefore, is intended to lessen the consequences of blade contact when it occurs, despite the use of the other safety devices present on the saw. This approach is consistent with the concept of making systems more "forgiving" of errors that will occur inevitably, so that the results are not catastrophic (Hammer, 1972; Senders & Moray, 1991; Woodson, 1998).

SawStop's detection and reaction system includes two components: an electronic detection unit and a brake. The two components are contained within a brake cartridge, which is positioned under the table and just behind the blade (see Figure 8). The system induces a small electrical signal onto the saw blade. When human skin contacts the blade, the person's body absorbs part of this signal. The system detects the consequent signal reduction and engages the brake. The brake consists of an aluminum pawl that is pushed into the teeth of the spinning blade, stopping it

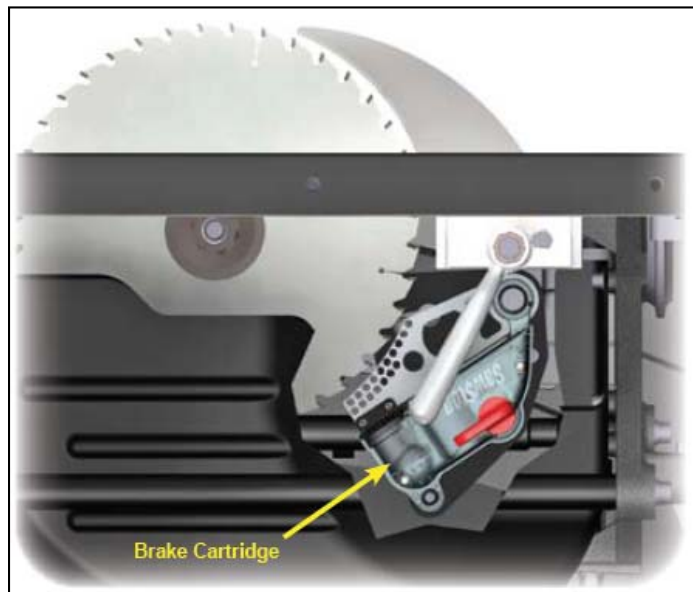

Figure 8. Brake cartridge location.

Reprinted from *10" contractor saw: Owner's manual* (p. 9), by SawStop, LLC, 2008, Tualatin, OR: Author. Copyright 2008 by SawStop, LLC. Used with permission.

in milliseconds. If the blade is at or near full speed when the brake is activated, the blade also quickly retracts below the table surface. In principle, when the system functions as intended, the only injury likely to be sustained by direct contact with the saw blade is a small cut.⁵ If the system is activated, a new brake cartridge must be installed before the saw can be used again. To staff's knowledge, SawStop is the only manufacturer currently employing safety technology of this type; however the Power Tool Institute recently has developed similar technology.⁶

SAMPLE SYSTEM INSTALLATION AND REMOVAL

In 2009, the CPSC's Mechanical Engineering and Human Factors staff obtained and examined a sample of a SawStop contractor saw. The saw was received with a brake cartridge preinstalled. If the system activates, this brake cartridge will need to be replaced. Activation of the system will most likely result in the saw blade becoming embedded in the cartridge's brake pawl and the blade retracting below the table. This situation would require the consumer to reset the arbor block into its retraction bracket and remove the saw blade and cartridge together. To reset the arbor block, the consumer must fully lower the blade to the lower elevation limit stop, at which point the arbor block will automatically engage the support mechanism. Then the consumer can raise the blade to maximum height, remove the table insert, and remove the blade guard system to access the blade and brake cartridge.

To remove the blade and the brake cartridge, the consumer must remove the blade nut and washer from the arbor and then remove the red cartridge key that locks the cartridge in place (see Figure 9). The key can be removed by rotating it 90 degrees clockwise and pulling it out. Then the cartridge can be pulled away from its mounting bracket and off its two mounting pins—a large pivot pin and a small positioning pin—while the saw blade is simultaneously pulled off the arbor. CPSC staff found this task to be extremely difficult and time-consuming, with the blade-cartridge “assembly” binding in place. Removal required the use of tools to lever the cartridge off the arbor.

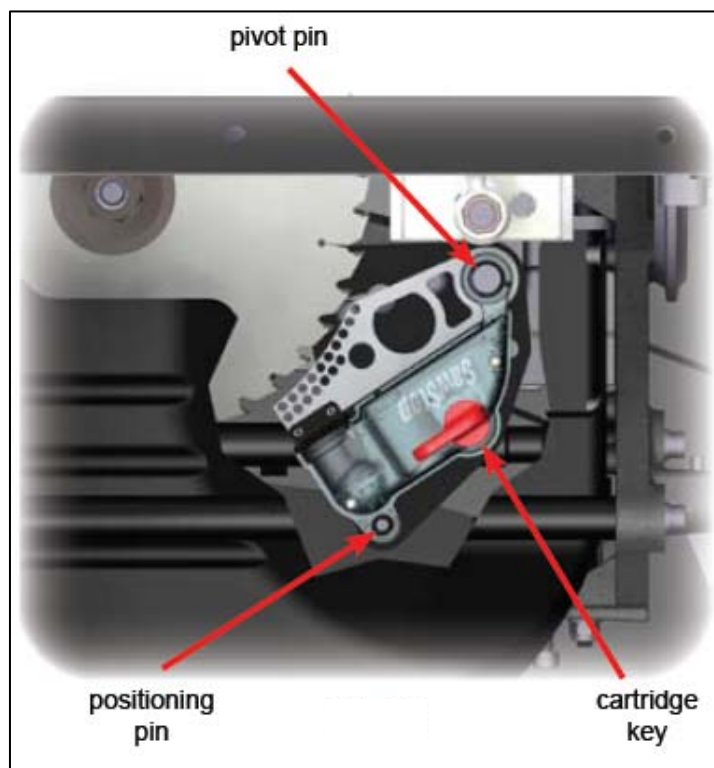

FIGURE 9. Installed brake cartridge.

Adapted from *10" contractor saw: Owner's manual* (p. 54), by SawStop, LLC, 2008, Tualatin, OR: Author. Copyright 2008 by SawStop, LLC. Used with permission.

⁵ Human Factors staff presumes that a more substantial injury may be possible if movement into the blade is extremely rapid. The approach speed required for such injury, however, has not yet been determined by staff.

⁶ In a meeting with Commission staff in June 2011, the Power Tool Institute discussed and showed video footage of their technology, which also retracts the saw blade upon detecting blade contact with the skin. According to the Power Tool Institute, SawStop has stated that this system likely will infringe SawStop's patents.

Installing a new brake cartridge requires the consumer to align two mounting holes on the brake cartridge with the two mounting pins in the saw. Once aligned, the cartridge slides onto these pins and is pushed against the mounting bracket. When the cartridge is pushed into place, a computer connector on the side of the cartridge self-aligns with a corresponding computer cable in the saw. Then the cartridge key is inserted into the cartridge and is rotated 90 degrees counterclockwise to lock the cartridge into place. Once the cartridge is installed, the consumer is instructed to check the spacing between the cartridge and the blade and, if necessary, adjust a brake positioning bolt to fine-tune this distance. Consumers must perform this blade-cartridge distance check each time a new blade or cartridge is installed.

Visually aligning the two mounting holes with the mounting pins is difficult, given the mounting location below the surface of the table. To ease alignment, consumers may choose to rely upon the prominent computer connector on the side of the cartridge as a cue to indicate the proper orientation of the cartridge during installation. For example, consumers may partially insert the large pivot pin into the large mounting hole on the cartridge, rotate the cartridge until the computer connector and cable align, and then push the cartridge against the mounting bracket. Human Factors staff was able to install the cartridge fully in this manner, including locking the cartridge key, only to discover that the saw would not start. Although staff has concerns about the ability to fully install the cartridge incorrectly, the system is designed so that the motor will not start unless the cartridge is installed correctly. Staff also notes that there was no information on the brake cartridge, on the cartridge packaging, or within the packaging, regarding how to install the cartridge properly. Given the importance of correctly installing the cartridge, staff believes this information should be provided with every replacement cartridge.

SAMPLE SYSTEM USE AND OPERABILITY

SawStop's blade-contact detection and reaction system does not seem to interfere with most saw operations. The system cannot be used when cutting aluminum, brass, or other conductive materials, but in most cases, consumers will not have to cut these materials, and will never have to bypass the system. In the rare event that they do, consumers must insert a bypass key, pull out the start/stop paddle to the ON position, and hold the key turned for another second after the motor starts. While performing this action repeatedly no doubt would be a nuisance for consumers who intend to cut a large amount of conductive materials, most consumers are likely to be unaffected or minimally affected.

The system does require consumers to change the cartridge whenever switching to or from dado sets, which require the use of an optional dado brake cartridge that has a larger brake pawl than is used with 10-inch standard blades. Consumers may find this rather inconvenient if they must perform the switch often. SawStop also recommends that the brake cartridge be replaced if more than a "small amount of dust" can be seen inside the cartridge's clear housing. Consumers are unlikely to take the time to inspect the cartridge regularly, and it is unclear whether consumers who do take this action would be able to determine whether the amount of dust present would warrant replacement based on SawStop's recommendation.

CONCLUSIONS

Newer blade guard systems appear to be a significant improvement over most traditional blade guard systems; however, even the new blade guard systems will not physically prevent all blade-contact injuries that result from the hand approaching the front, or leading portion, of the blade. Furthermore, the new blade guard system that staff examined still can hinder certain table saw tasks and prevent the performance of certain sawing tasks, encouraging removal of the blade guard system. Removing the system is easy, but installation is somewhat trickier, and if repeated installation is necessary, it might be time-consuming and burdensome. These characteristics might motivate some consumers—especially experienced or expert woodworkers—to forego reinstalling the system once removed.

Unlike blade guard systems, which are intended to reduce consumer exposure to the blade in the first place, a blade-contact detection and reaction system such as that developed by SawStop functions as a secondary safety system that lessens the consequences of blade contact when it occurs. This system is not intended as a replacement for blade guards and kickback prevention devices. Blade guard systems, whether the new blade guard system or the more traditional variety, are intended to reduce consumer exposure to the blade and are important to help prevent kickback and blade contact in the first place. The SawStop system that staff examined does not seem to interfere with most saw operations, and once it is installed the system is essentially invisible to the consumer until it is needed. Removing and reinstalling the brake cartridge when switching to and from dado sets, or once the system has been activated, can be difficult. However, in all likelihood, system activation would occur only after contact with the skin, a situation in which the consumer very well might have sustained serious injury had the system not been in place.

REFERENCES

- Adams, M. (2010, March 29). Woodworking essentials: Table saws. *Popular Woodworking Magazine*. [Online.] Available: http://www.popularwoodworking.com/techniques/woodworking_essentials_table_saws. (Obtained June 7, 2011.)
- Chowdhury, S. R., & Paul, C. (2011, March). *Survey of injuries involving stationary saws: Table and bench saws 2007–2008*. U.S. Consumer Product Safety Commission Staff Report. Washington, DC.
- Cushman, W. H., & Rosenberg, D. J. (1991). *Advances in human factors/ergonomics: Vol. 14, Human factors in product design* (G. Salvendy, Series Ed.). New York: Elsevier.
- Geller, E. S. (2001). *The psychology of safety handbook*. Boca Raton, FL: Lewis.
- Hammer, W. (1972). *Handbook of system and product safety*. Englewood Cliffs, NJ: Prentice-Hall.
- Mehler, K. (2003). *The table saw book* (Rev. ed.). Newton, CT: Taunton.
- Nemeth, C. P. (2004). *Human factors methods for design: Making systems human-centered*. Boca Raton, FL: CRC Press.
- Nussbaum, J. A. (1998). Paying a terrible price. *Occupational health & safety*, 67(12). 28, 30, 51.
- Power Tool Institute, Inc. (2002). *Power tool “safety is specific”: Guidelines for the safe operation of widely used portable, and stationary power tools*. [Online.] Available: <http://www.powertoolinstitute.com>. (Obtained July 2, 2008.)
- Reason, J. (1990). *Human error*. New York: Cambridge.
- Riley, D. M. (2006). Beliefs, attitudes, and motivation. In M. S. Wogalter (Ed.), *Handbook of warnings* (pp. 289–300). Mahwah, NJ: Lawrence Erlbaum Associates.
- Robert Bosch Tool Corporation. (2007). *Bosch 4100/4100DG operating/safety instructions*. Prospect, IL: Author.
- SawStop, LLC. (2008). *10" contractor saw: Owner's manual*. Tualatin, OR: Author.
- Senders, J. W., & Moray, N. P. (1991). *Human error: Cause, prediction, and reduction*. Hillsdale, NJ: Lawrence Erlbaum Associates.
- Tolpin, J. (2004). *Jim Tolpin's table saw magic* (2nd ed.). Cincinnati, OH: Popular Woodworking Books.
- Trump, T. R. (1980). Product induced inconvenience and the unsafe act. In H. R. Poydar (Ed.), *Proceedings of the symposium: Human factors and industrial design in consumer products* (pp. 433–440). Medford, MA: Tufts University.

Woodson, W. E. (1998). *Human factors engineering for forensic and safety specialists*. Tucson, AZ: Lawyers & Judges.

Zimolong, B. M., & Elke, G. (2006). Occupational health and safety management. In G. Salvendy (Ed.), *Handbook of human factors and ergonomics* (3rd ed., pp. 673–707). Hoboken, NJ: Wiley.